Wind Alarm Instrument 3

4.3242.0x.00x



ADOLF THIES GmbH & Co. KG

Hauptstraße 76

Box 3536 + 3541

Phone ++551 79001-0

www.thiesclima.com

37083 Göttingen Germany

37025 Göttingen

Fax ++551 79001-65

info@thiesclima.com

Contents

1	Models	2
2	Range of Application.....	3
3	Mode of Operation	3
4	Recommendation Site Selection.....	3
5	Mounting	4
5.1	Mechanical Mounting	4
5.2	Electrical Mounting	4
6	Circuit Diagram	4
7	Operation	7
7.1	View.....	7
7.2	Setting the Wind Alarm Threshold:.....	8
7.3	Switch-On Delay:.....	8
7.4	Switch-Off Delay:.....	9
8	Maintenance	9
9	Technical Data.....	10
10	Dimensional Drawings.....	10
11	EC-Declaration of Conformity	11

1 Models

Order Number	Construction	Supply Voltage
4.3242.01.000	Panel mounting	230 V / 50 Hz
4.3242.01.001	Panel mounting, with additionally integrated acoustic signal transmitter	230 V / 50 Hz
4.3242.05.000	Panel mounting	15 V DC
4.3242.06.000	Panel mounting	18... 25 V DC
4.3242.08.000	Panel mounting	115 V / 50 Hz
4.3242.14.000	Euro- Card	230 V / 50 Hz
4.3242.15.000	Euro- Card	15 V DC
4.3242.16.000	Euro- Card	18... 25 V DC

2 Range of Application

Wind Alarm Instrument 3 is used in conjunction with a wind transmitter (4.3303.22.000) to initiate preventive measures to protect wind-endangered objects such as, for example, cranes, bridges, masts, greenhouses, window blinds and awnings.

3 Mode of Operation

The wind transmitter (4.3303.22.000) delivers impulses proportionally to the wind velocity. These pulses are acquired and processed by the wind alarm instrument 3.

The wind alarm is released by a relay. If the wind velocity exceeds a preset value the relay switches after a certain delay and releases the alarm. If the wind velocity falls below the preset value, the relay deactivates after a certain delay.

The switch-on- and switch-off-delay prevents the relay from permanently switching-over in case of short-term exceeding or falling below the threshold. The delay periods are selectable by means of a rotary switch.

Example of a Wind Alarm System:

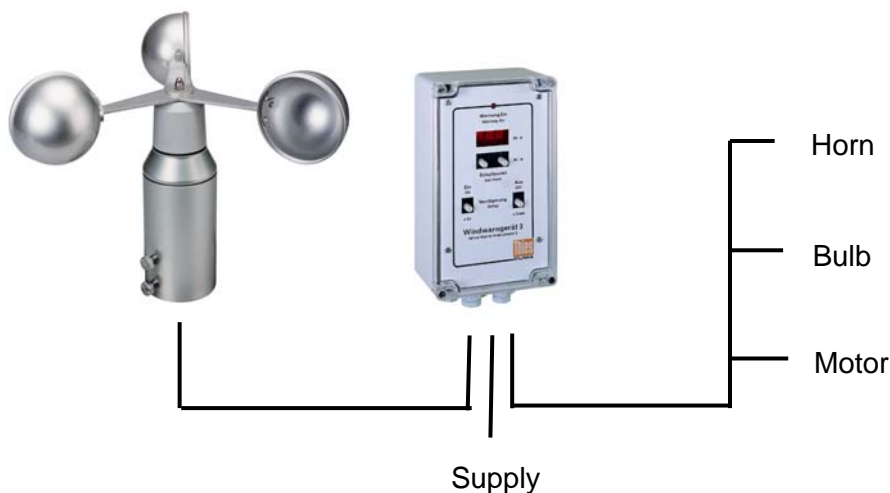

4 Recommendation Site Selection

The wind alarm instrument 3 is designed for indoors mounting. In case of outdoor application an additional over-housing with the respective protection is necessary.

Remark

Please pay attention to the temperature application range when selecting a site.

5 Mounting

Caution

The device should only be installed and connected by qualified technicians. The general engineering regulations and provisions and standards applicable must be observed.

5.1 Mechanical Mounting

Construction: Panel mounting

The Wind Alarm Instrument 3 is designed to be mounted to walls in roofed-over rooms. To do this, first unscrew the transparent cover, revealing the four screw borings. Now mount the instrument to the wall by inserting 4 mm screws into these four borings.

Construction: Euro- Card

The complete pc-board is put into the guide track of a suited card hopper so that the male multipoint connector catches the female multipoint connector of the card hopper.

5.2 Electrical Mounting

Connect the instrument electrically in accordance with the following circuit diagrams as appropriate for the wind transmitter being used. This must be carried out by an electrician or some other expert.

Remove the white front plate. Lead the connecting lines through the respective screw-type conduit fitting and connect as shown in the combination circuit diagram (see Chapter 6).

The following recommendation applies for the operation of a wind transmitter with heating:

0,75 mm² cable lead cross section, max. 50 m length of lead

6 Circuit Diagram

Attention:

Circuit diagrams below shows the relay in "alarm off" position. The condition is valid when operating voltage is supplied to the wind warn unit and alarm set point is not reached.

Order- No.

4.3242.01.000
4.3242.01.001
4.3242.08.000

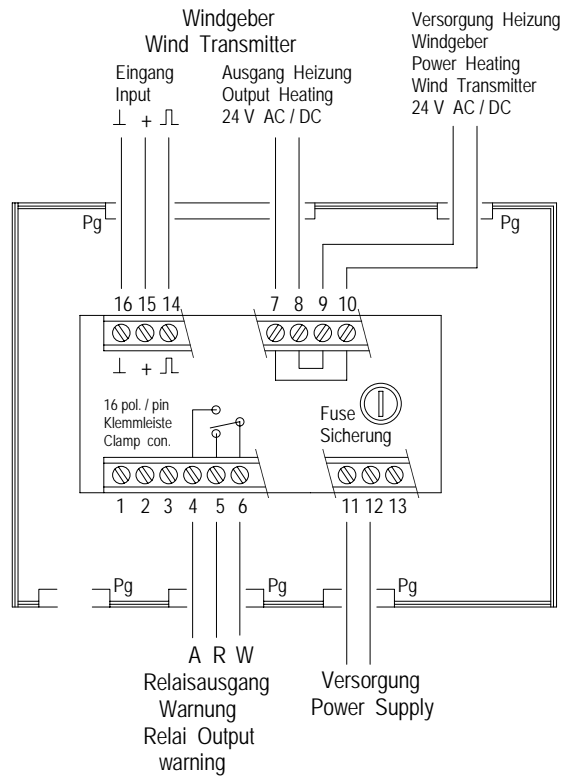

Order- No.

4.3242.06.000

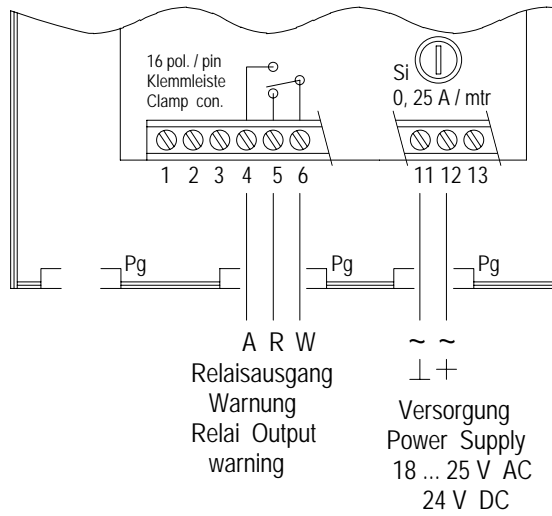

Order- No.

4.3242.05.000

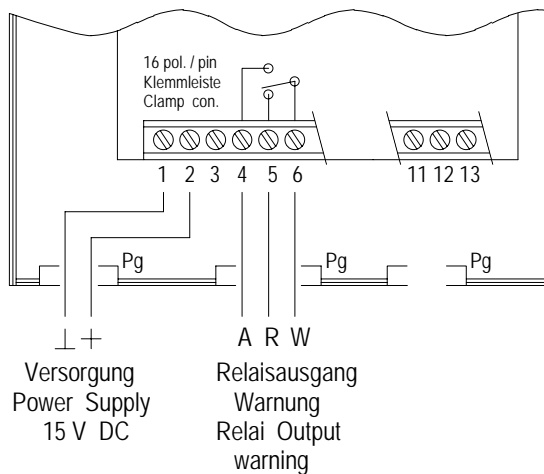

Order- No.

4.3242.14.000

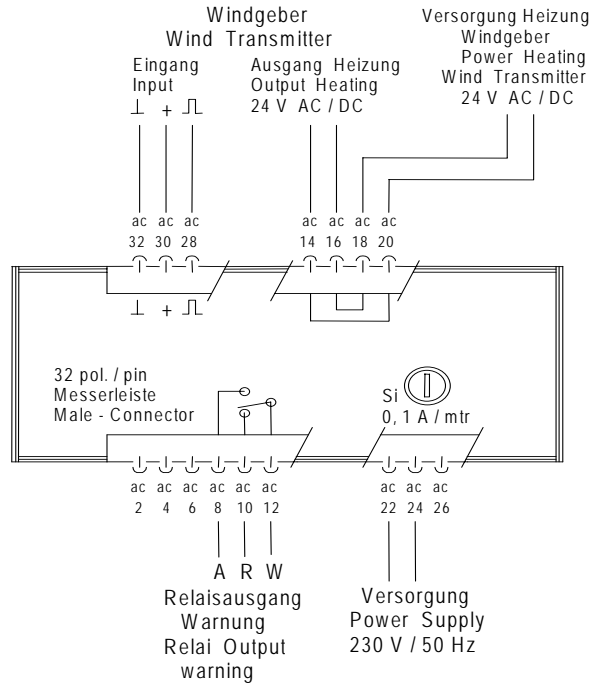

Order- No.

4.3242.16.000

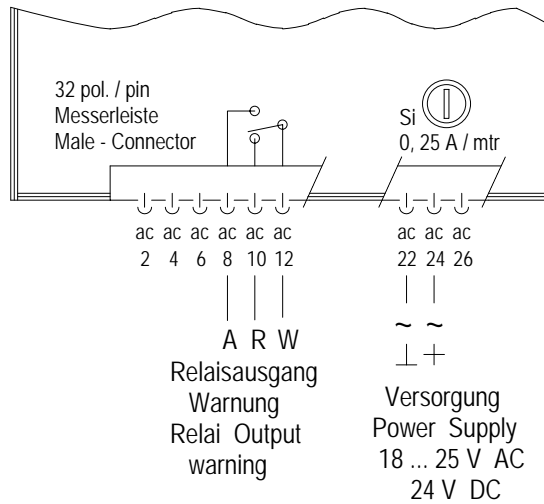

Order- NO.

4.3242.15.000

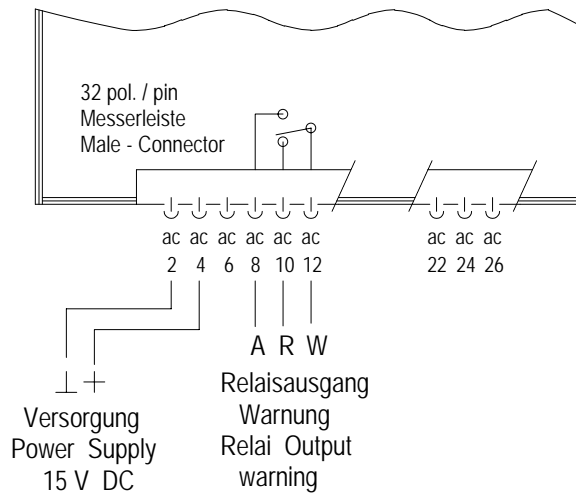

7 Operation

The positions (0...9) of the rotary switches for the settings are marked with the model "wall housing". With model „Euro-card“ the arrangement is identical with model „wall housing“.

A 3-digit LED display indicates the instantaneous value of the wind velocity.

An LED signals the alarm status: red = threshold exceeded / wind alarm on.

7.1 View

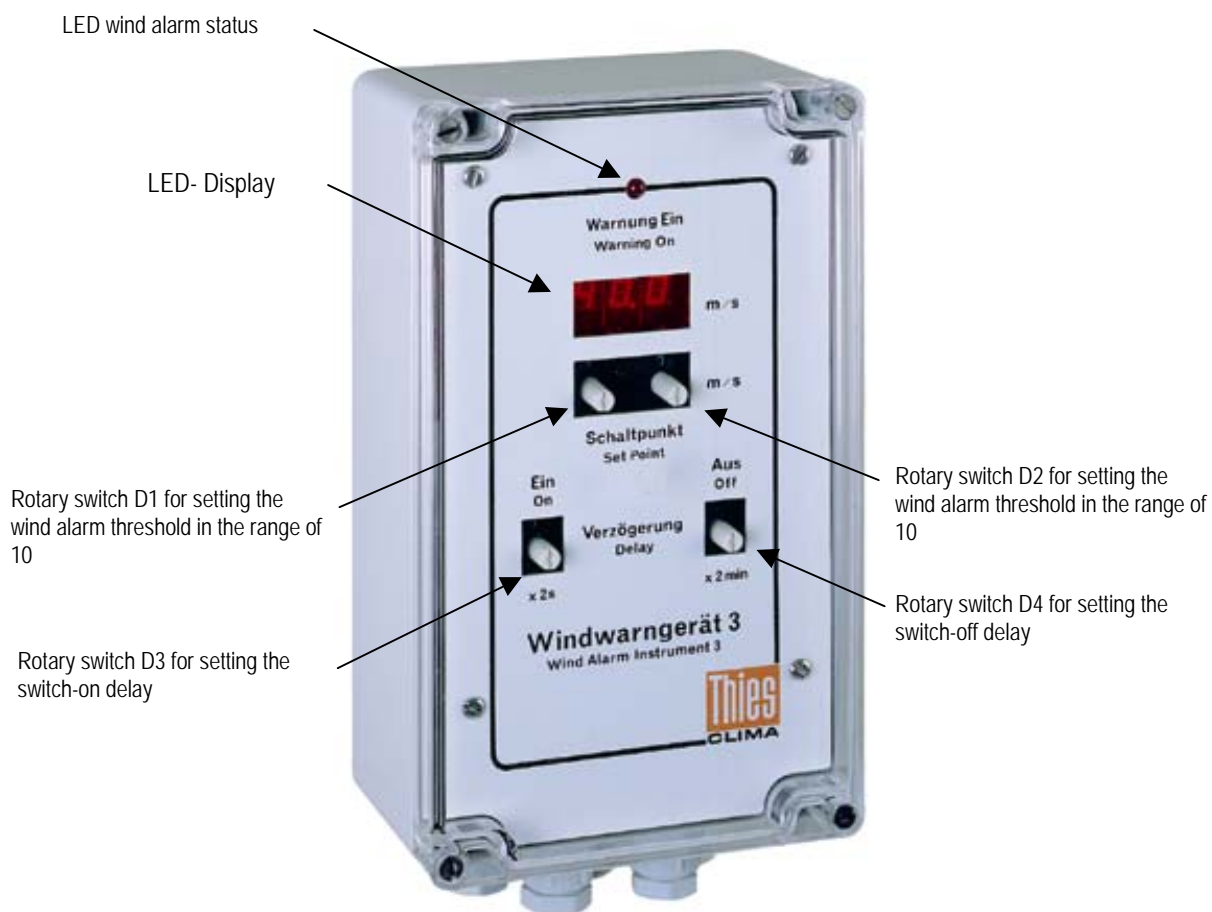

7.2 Setting the Wind Alarm Threshold:

The threshold is set in double figures directly; hereby, the figures appearing in the field display the value.

The switching point of the wind alarm threshold is selectable in the range from 0...50 m/s by means of the **rotary switches 1 and 2**.

Rotary switches 1 range of 10	Rotary switches 2 range of 1	Alarm threshold
Position	Position	Depending on position
0	0	1 –50 m/s
1	1	
2	2	
3	3	
	4	
	5	
	6	
	7	
	8	
	9	

Setting example: R1 = 2 and R2 = 1 = Alarm threshold **21** m/s

7.3 Switch-On Delay:

By means of **rotary switch 3** the switch-on delay of the wind alarm is set for the case of a permanent exceeding of the wind alarm threshold .

The switch-on delay is set in single figure from 0...18 seconds in switch positions of 10. Please consider that the figure appearing in the window is to be multiplied by „2“.

Rotary switch 3	Switch-on delay
Position	[Seconds]
0	0
1	2
2	4
3	6
4	8
5	10
6	12
7	14
8	16
9	18

Setting example: R3 = 3 = Switch-on delay **6** sec

7.4 Switch-Off Delay:

By means of **rotary switch 4** the switch-off delay of the wind alarm is set for the case of a permanent falling below the wind alarm threshold.

The switch-off delay is set in single figure from 0...18 minutes in switch positions of 10. Please consider that the figure appearing in the window is to be multiplied by „2“.

Rotary switch 4	Switch-off delay
Position	[Minutes]
0	0
1	2
2	4
3	6
4	8
5	10
6	12
7	14
8	16
9	18

Setting example: R4 = 5 = Switch-off delay **10** min

After completion of all mounting- and setting works the wind alarm instrument 3 is to be closed again by installing the front plate and clear cover.

8 Maintenance

With proper mounting the instrument operates maintenance-free.

Remark:

Please pay attention to maintenance advices of the wind transmitter

9 Technical Data

Order- No.	4.3242.01.000 4.3242.05.000 4.3242.06.000 4.3242.08.000	4.3242.14.000 4.3242.15.000 4.3242.16.000
Wind alarm range	0...50 m/s	0...50 m/s
Resolution	1 m/s	1 m/s
Measuring value input	Pulses (0- 1042Hz = 0- 50 m/s)	Pulses (0- 1042Hz = 0- 50 m/s)
Switch-on delay	1...18 sec.	1...18 sec.
Switch-off delay	1...18 min.	1...18 min.
Relay output	throw-over switch, one-pole, potential-free	throw-over switch, one-pole, potential-free
Contact rating	200 W, 24 V DC, 100 W, 250 V DC 1000 VA, max. 8 A	200 W, 24 V DC 100 W, 250 V DC 1000 VA, max. 8 A
Operating voltage	See model	See model
Ambient temperature	0...40° C	0...40°C
Construction	Panel mounting	Euro- Card
Connection	Screwed cable gland, connecting strip, 16 pole	Terminal strip, 32-pole
Dimensions	120 x 200 x 75 mm	approx. 100 x 170 x 50 mm
Type of protection	IP 65 acc. DIN 40050	Mounted in card hopper
Weight	0.85 kg	0.3 kg

10 Dimensional Drawings

Construction: Panel mounting

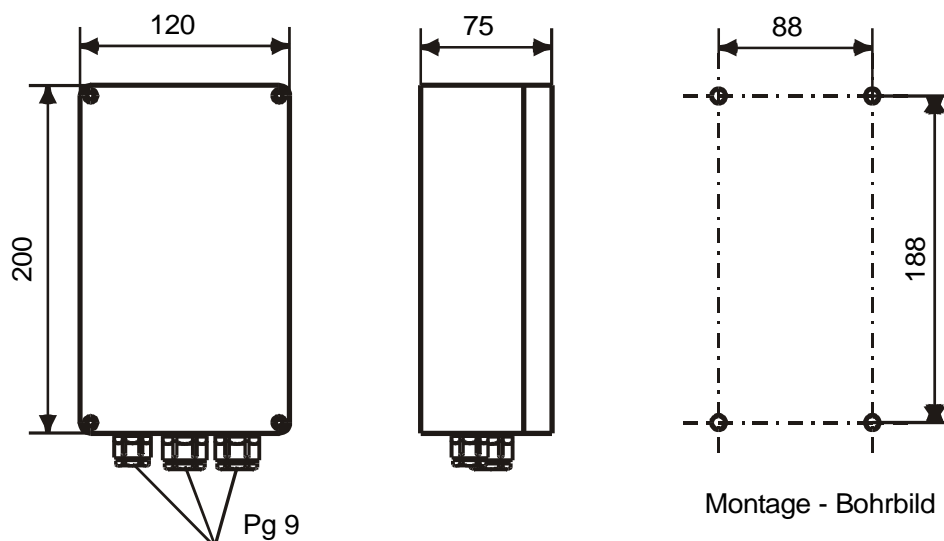

11 EC-Declaration of Conformity

Document-No.: **001290**

Month: 06 Year: 08

Manufacturer: **ADOLF THIES GmbH & Co. KG**

Hauptstr. 76
D-37083 Göttingen
Tel.: (0551) 79001-0
Fax: (0551) 79001-65
email: Info@ThiesClima.com

Description of Product: **Wind Alarm Instrument**

Article No.	4.3241.00.000	4.3241.00.001	4.3241.02.000	4.3241.02.001
	4.3241.02.900	4.3241.03.000	4.3242.01.000	4.3242.02.000
	4.3242.05.000	4.3242.06.000	4.3242.14.000	

specified technical data in the document: **020713/04/08; 020534/02/99**

The indicated products correspond to the essential requirement of the following European Directives and Regulations:

- 2004/108/EC DIRECTIVE 2004/108/EC OF THE EUROPEAN PARLIAMENT AND OF THE COUNCIL of 15 December 2004 on the approximation of the laws of the Member States relating to electromagnetic compatibility and repealing Directive 89/336/EEC
- 2006/95/EC DIRECTIVE 2006/95/EC OF THE EUROPEAN PARLIAMENT AND OF THE COUNCIL of 12 December 2006 on the harmonisation of the laws of Member States relating to electrical equipment designed for use within certain voltage limits
- 552/2004/EC Regulation (EC) No 552/2004 of the European Parliament and the Council of 10 March 2004 on the interoperability of the European Air Traffic Management network (the interoperability Regulation)

The indicated products comply with the regulations of the directives. This is proved by the compliance with the following standards:

Reference number	Specification
IEC 61000-6-2: 2005	Electromagnetic compatibility Immunity for industrial environment
IEC 61000-6-3: 2006	Electromagnetic compatibility Emission standard for residential, commercial and light industrial environments
IEC 61010-1: 2001	Safety requirements for electrical equipment for measurement, control and laboratory use. Part 1: General requirements

Place: Göttingen

Date: 27.06.2008

Legally binding signature:

issuer:

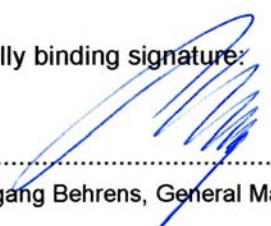
.....
Wolfgang Behrens, General Manager

.....
Joachim Beinhorn, Development Manager

This declaration certifies the compliance with the mentioned directives, however does not include any warranty of characteristics. Please pay attention to the security advises of the provided instructions for use.



ADOLF THIES GmbH & Co. KG

Hauptstraße 76 37083 Göttingen Germany
P.O. Box 3536 + 3541 37025 Göttingen
Phone ++551 79001-0 Fax ++551 79001-65
www.thiesclima.com info@thiesclima.com



- Alterations reserved -